

RIBA   
 ×  
 ALUR

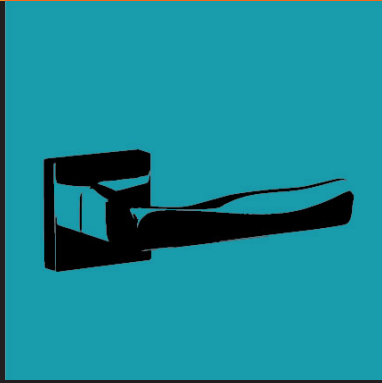

# My Home is My Castle Design Competition

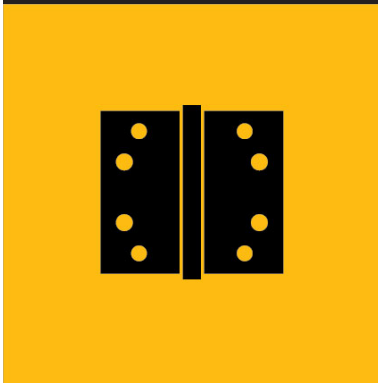

# Briefing

---

12<sup>th</sup> June 2020

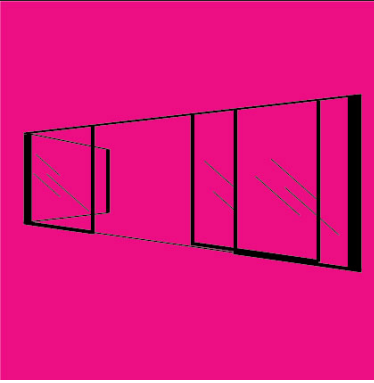
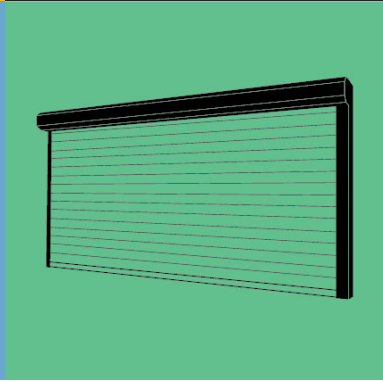
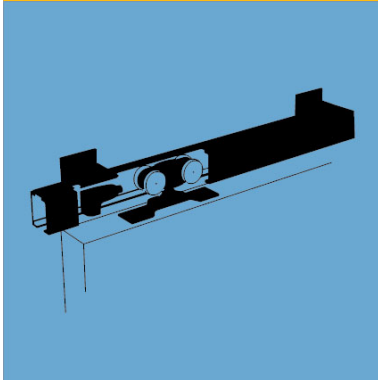
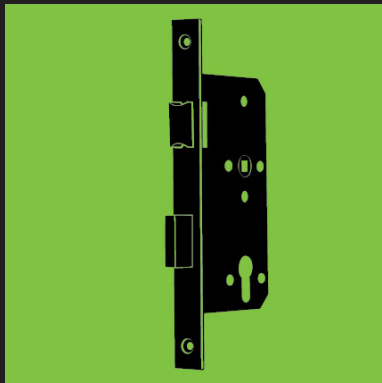

# 1) Summary

The Competition aims to call for Design concepts focusing on the Main Entrance of apartments and homes in Hong Kong. Submissions can cover the design of a lever or pull handle as a product or the experience of entering a home as a holistic approach. As such, two Categories of Entries have been defined.

## **A. Control & Move the Door**

## **B. Vision of Entrance**

Submissions are due on or before 15 August 2020 and are open to any individual or company from the Design Community of Hong Kong and Macau.

# 2) Overall Intention

RIBA, in cooperation with AUB Ltd are intending to launch a design competition under the theme of **“My Home is My Castle”**.

As the Covid-19 Virus is ravaging on around the globe, people living in densely populated areas such as Hong Kong and Macau are seeking more than ever before to protect their families and to ensure their home as a first refuge.

The sense of safety and security has always been high, yet the technology deployed at the main entrance door to an apartment has evolve—d very little over time.

Mechanical solutions such as standard door knob, lever handles, cylinder & key, metal gates with semi-industrial locks and old fashioned keys and the likes have long been the standard means of locking, opening and entering our homes.

Only in the last few years, electronic locks based on Pin, Card, Finger-print or Mobile App’s have found their way to modern apartments main doors.

Still, have our needs for design, smart technology and individualized solutions really been addressed?

Do we like to have a nice looking door to our home with smoothly integrated locking devices?

Are we dreaming of a futuristic entrance design allowing us to enter the home touch-free and automatic?

Should the lever- or pull handle express my personality and lifestyle?

Well, we believe that there is room for imagination and creativity to be articulated and for related solutions and items to be proposed.

We like to call on the design community to help to create a new experience to enter a home or apartment by means of a holistic approach including the door itself, the items necessary to control and move the door as well as the human interaction with them.

## 3) Design intent – Creative approaches

Whereas the competition is open to any creative approach one can think of possible design intents as outlined here below.

Again, these are suggestions and do not set out limitations as we like to encourage the community to allow creativity to flow freely in various directions.

### - **Jump out of the box**

- Create a totally new, unheard-of solution which you might think is crazy but is fun to use and to look at every day with a big smile.

### - **Proudly Hong Kong**

- Tradition lives on – with a touch. A solution which blends-in with the realities of Hong Kong traditional residential buildings, apartments and their physical constraints

### - **Form & Function**

- A practical solution which integrates all functional requirements yet offers a high level of design & form to please the owner's eye and standard of living.

## 4) Categories

The proposal can be submitted in either of the following two categories:

### **A. Control & Move the Door**

- starting point is the holistic approach considering the entire experience of the entrance
- yet, the selected focus is on the lever or pull handle or a newly created way of moving the door based your imagination as part of the overall concept of entrance
- the proposal is aimed at providing a product design which eventually is fully functional, can be engineered and produced so it can be marketed as a standard solution in the future

### **B. Vision of Entrance**

- focus on the entire experience related to the entrance of an apartment.
- Concept study only ie it is the intention to provide an overall vision of a new way to enter the home considering all elements
- Concept study only ie it is the intention to provide an overall vision of a new way to enter the home considering all elements

## 5) Criteria of assessment

The panel will assess the submissions based on the following set of criteria:

- **Ingenuity**
- **Functionality**
- **Variation**
- **Consistency**
- **Execution**
- **Presentation**
- **In Line with chosen category**

## 6) Regulatory Requirements

Overall, regulatory requirements should be considered as guidelines only, as listed below. These are not “hard” criteria which must be met:

- Manual Swing doors must “Swing inward”
- Typical dimensions of a residential door are 850(W)x2050(H)x50(D)
- Sliding doors should either be manual, or, in case of automatic, have a fail-safe manual release mechanism
- Fire Rated door FFR60min; as a total system, ie including door panel and necessary hardware components.—
- Materials of the door and its components: Wood, Steel, Brass, Zinc-Alloy, PE
- The assessment of materials regarding their compliance with the respective regulatory requirements shall not form part of the competition evaluation and judgment process
- Samples of lever handles, lock case, hinges etc are available at AUB Showroom or upon request

## 7) Eligibility

- An individual, a group or a company
- Working or studying a Design discipline in Hong Kong or Macau

## 8) Submission

### Documents

- Design Proposal (landscape) A3 x 2
- Contacts / Company info / Bio A4
- Copyright agreement if you deem it necessary

### Content

- Name of the Concept / Submission
- How it works - description in words (max500)

Submissions shall be delivered on or before **August 15, 2020** to **HongKong.Chapter@riba.org** either via email or a Wetransfer link. Attachment size shall not exceed **10MB**

## 9) Timelines

	<b>Timing</b>	<b>Channel / Event</b>
Launch Event	June 12	Zoom / FB Video online
Submission deadline	August 15	
Evaluation of submissions	Aug / Sep	Panel
Award	End Sep	
Ceremony	To be announced	

## 10) Judging Panel

### Organization

<b>Chair</b>	Martin Williams / RIBA HK
<b>Member</b>	Dianna Tang / Representative from RIBA HK
<b>Member</b>	NN / Guest from RIBA HK
<b>Member</b>	Andreas Brechbuhl / AUB Ltd
<b>Member</b>	NN / Representative Ironmongery Industry

## 11) Awards / Categories

- Prizes in each category (see 4. above)
- HKD5,000 for top 3 in each Category after Round 1
- HKD10,000 Winner Overall after Round 2
- Winner concept will be presented in 3D / life size mockup at Ceremony event (to be confirmed)
- Separate agreement with Winner re commercialization of concept

## 12) Outlook

AUB Ltd will consider to further develop the winning submission in Category A into a prototype and further into a standard item which can be mass produced and marketed in Hong Kong and other markets

## 13) About

RIBA Hong Kong Branch - International Chapters provide a dedicated forum for members and local practitioners to meet and exchange ideas on issues relevant to the profession. The Chapter is about connecting members and collectively promoting cultural discourse to strength the interests of the RIBA and raise the profile of the professional regionally as well as globally.

<https://www.architecture.com/my-local-riba/riba-hong-kong-chapter>

AUB Ltd is a private company established in Hong Kong, providing Door Access Solutions for Commercial, Institutional and Residential projects in Hong Kong and Macau.

[www.aub.com.hk](http://www.aub.com.hk)